

Metal-enclosed belt alignment switches for monitoring conveyor belts

In conveyor belt applications, the safety switch prevents conveyor belts from being damaged or being destroyed as the result of the belt running off track. When the roller lever is deflected by a conveyor belt running off track the safety contacts in the switch engage, thus shutting down the conveyor belt.

Only after eliminating the cause of the malfunction can the system be restarted by means of the pull release (key ring).

The roller lever is mounted in ball bearings. The cast iron enclosure has three M20 x 1.5 cable entries ready for through-wiring. The belt alignment switch is equipped with 2 normally-open contacts and 2 positive opening NC contacts ⊖. Thanks to its sturdy design, the device guarantees continuous trouble-free operation even under extreme operating conditions.

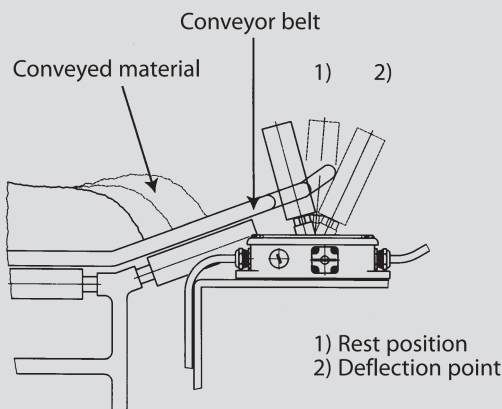

Product selection

Part number	Designation
6015736003	Si2-U2Z AW R-Rast

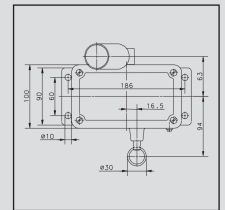

Technical data

Electrical data	
Rated insulation voltage	U _i max. 400 V
Rated operating voltage	U _e max. 240 V AC
Conventional thermal current	I _{the} 10 A
Utilisation category	U _c / I _e AC-15, U _c / I _e 240 V / 3 A
Positive opening action	⊖ as per IEC/EN 60947-5-1, Addendum K
Short-circuit protection	Fuse 10 A gL/gG
Protection class	I
Mechanical data	
Enclosure	Cast iron
Cover	Cast iron
Actuation	Roller lever
Ambient temperature	- 30°C to + 80°C
Contact type	2 NC / 2 NO contact (Zb)
Resetting the lock	Pulling the keyring (< 50 N)
Mechanical service life	2 x 10 ⁶ switching cycles
Switching frequency max.	≤ 10 / min.
Mounting	4 x M8
B10d	4 mill.
Type of connection	Screw connections
Conductor cross sections	Single-wire 0.5 – 1.5 mm ² or Stranded wire with ferrule 0.5 – 1.5 mm ²
Cable entry	3 x M20 x 1.5
Weight	≈ 4.1 kg
Installation position	Any
Protection class	IP 65 conforming to IEC/EN 60529
Standards	
VDE 0660 T100, DIN EN 60947-1, IEC 60947-1	
VDE 0660 T200, DIN EN 60947-5-1, IEC 60947-5-1	